

RESERVE COPY

PATENT SPECIFICATION



Convention Date (Germany) : July 7, 1938.

523,887

Application Date (in United Kingdom) : July 6, 1939.

No. 19743/39.

Complete Specification Accepted : July 24, 1940.

COMPLETE SPECIFICATION

A Rotary Valve for Controlling Internal Combustion Engines

We, BAYERISCHE MOTOREN WERKE AKTIENGESELLSCHAFT, a body corporate registered under the laws of Germany, of Lerchenauerstrasse 76, Munchen 13, Germany, do hereby declare the nature of this invention and in what manner the same is to be performed, to be particularly described and ascertained in and by the following statement:—

10 The invention relates to the construction of the control port slots of rotary valves of internal combustion engines.

In general the port slots of rotary valves are provided with straight, sharp edges.

15 This construction however has the considerable disadvantage that extremely unfavourable conditions of flow arise.

20 The present invention is adapted to counteract this by the particular construction of the port slots of the valve. According to the present invention all the control edges of the port slots are uniformly rounded on the outside. As a result there is obtained, whilst effecting better conditions of flow, an easier and better filling and a more rapid emptying.

25 The construction of the port slots, according to the invention, in a valve, is shown in the accompanying drawing, wherein:

30 Fig. 1 shows a longitudinal section, and

Fig. 2 a plan.

According to the invention the lateral control edges 1 and 2, as also the upper and lower edges 3 and 4 of the port slots 5 and 6 of the valve 7 are uniformly rounded on the outside. As a result there is obtained a gradual opening and closing of the port instead of a sudden opening or cut off, by the control edges, which is equivalent to a rapid filling, and a rapid emptying.

Having now particularly described and ascertained the nature of our said invention and in what manner the same is to be performed, we declare that what we claim is:

1. A rotary valve for controlling internal combustion engines with an inlet and outlet port arranged transversely to the axis of rotation characterised in that all the control edges of the port slots of the valve are uniformly rounded on the outside.

2. A rotary valve for internal combustion engines substantially as hereinbefore described with reference to the accompanying drawing.

Dated this 6th day of July, 1939.

H. FAIRBROTHER,
Chartered Patent Agent,
30 and 32 Ludgate Hill,
London, E.C.4.

Fig. 1

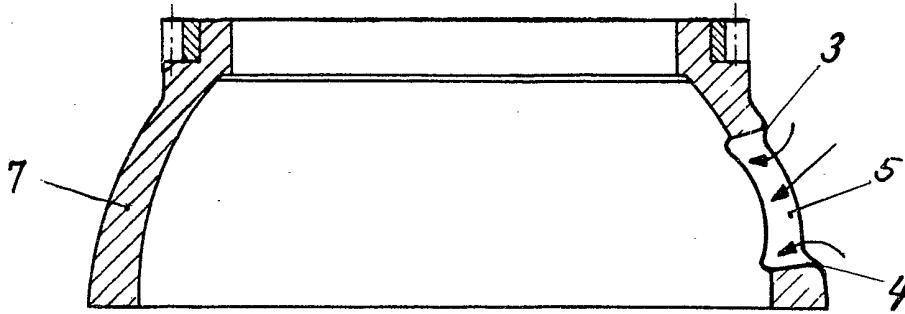
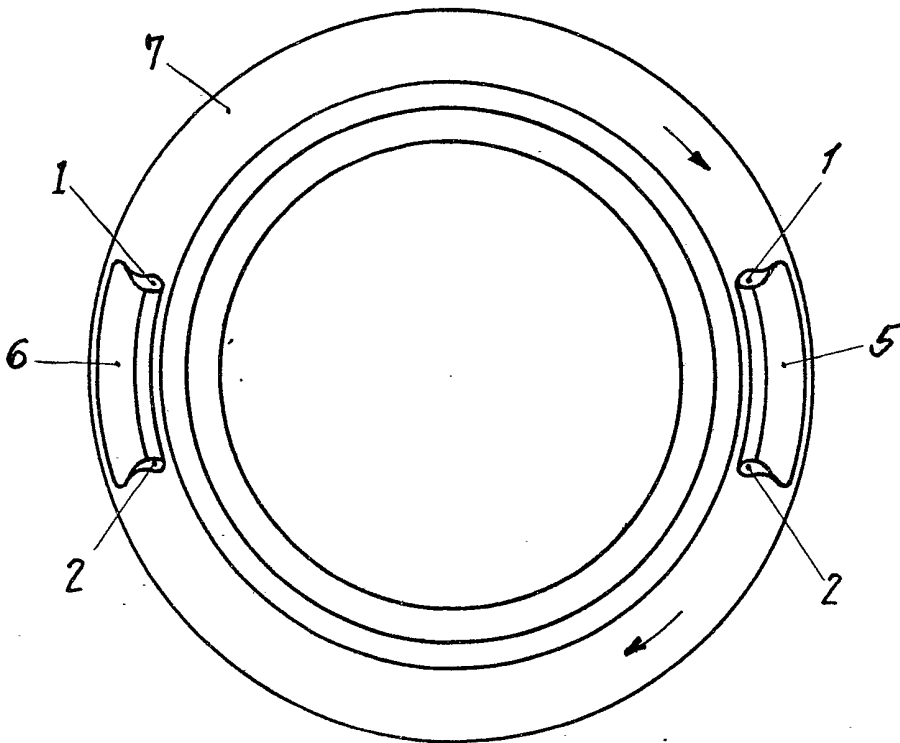

Fig. 2



[This Drawing is a full-size reproduction of the Original.]